

BC200 BRUSH CHIPPER



BC200 BRUSH CHIPPER

Vermeer



BUILT FOR THE DAILY GRIND.



All across Europe, tree care professionals agree that when it comes to tree removal equipment, safety, performance and quality matter most. The tough work of tree removal is a thing of the past. At least that's what we know to be true with Vermeer tree service equipment — particularly Vermeer brush chippers.

Built to withstand the daily grind, Vermeer brush chippers are equipped with exclusive features that promote ease of operation and high efficiency. They're also convenient to maintain and transport, creating value for arborists, contractors and tree care crews looking to maximize productivity and capitalize on secondary chip markets.



BC200 BRUSH CHIPPER

Designed for European tree care professionals who demand simplicity, productivity and ease of serviceability, the Vermeer BC200 brush chipper combines it all into a narrow package with ease of transport in mind.

Equipped with a Stage V-compliant, diesel or petrol engine, it offers maximized chipping productivity over its predecessor, the BC190XL brush chipper.

Able to chip branched material up to 20,3 cm (8 in), the BC200 has a two-step starting process with its direct drive system to maximize operator efficiency, while the Ecoldle™ engine control system optimizes fuel efficiency and minimizes noise. It's efficient and productive.

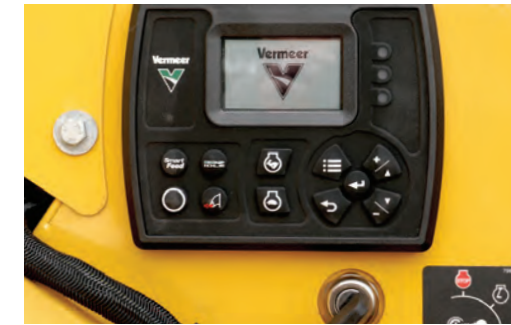

Two-step start and ease of operation

A two-step, turnkey starting process takes operators from startup to chipping in moments. An infeed button and switch control allow for ease of operation, and an offset roller makes it efficient to feed the machine. That's a good thing, given that the powerful pulling capacity and oversized infeed opening will keep your crew wanting to feed it more and more. Plus, the SmartFeed system monitors engine speed and stops or reverses the rollers if needed. This is chipping simplicity.



Stage V-compliant engines

The BC200 is equipped with an EU Stage V compliant Kubota® diesel or petrol engine. The diesel will deliver 44,3 hp (33.0 kW) while the petrol engine delivers 57 hp (42,5 kW) for best-in-class fuel capacity. The Ecoldle system is adjustable, helps save fuel and reduces noise by automatically reducing engine speed after one or five minutes of inactivity.



Ease of serviceability

Fewer doors mean more convenience. A one-piece pivoting engine hood provides optimal accessibility to internal components for ease of serviceability including chipper knives, anvil and grease points. This machine was designed to put wear parts well within reach.



Durable design

From the paint to the undercarriage, this brush chipper is equipped for the long haul. A heavy duty axle provides stability and durability during chipping and transport — particularly on bumpy road conditions. And the four-stage powder coating treatment helps protect the machine against time and weather to help it still look good long after it has chipped thousands of limbs and branches.



The Vermeer 3-year coverage

The BC200 comes with 3-year service coverage on select components with an option to extend up to 5 years/5,000 hours. It's a smart way to help protect your investment.

BC200 BRUSH CHIPPER WITH OPTIONAL TURNTABLE

Productivity comes full circle with the Vermeer BC200 brush chipper with optional turntable for seven machine positionings. Operators can reposition the machine without the use of a transport vehicle and feed material from multiple angles. This provides added versatility and operator convenience when working along the roadside or on narrow jobsites.

The BC200 with optional turntable includes the same features that make the BC200 a favorite among European tree care professionals.

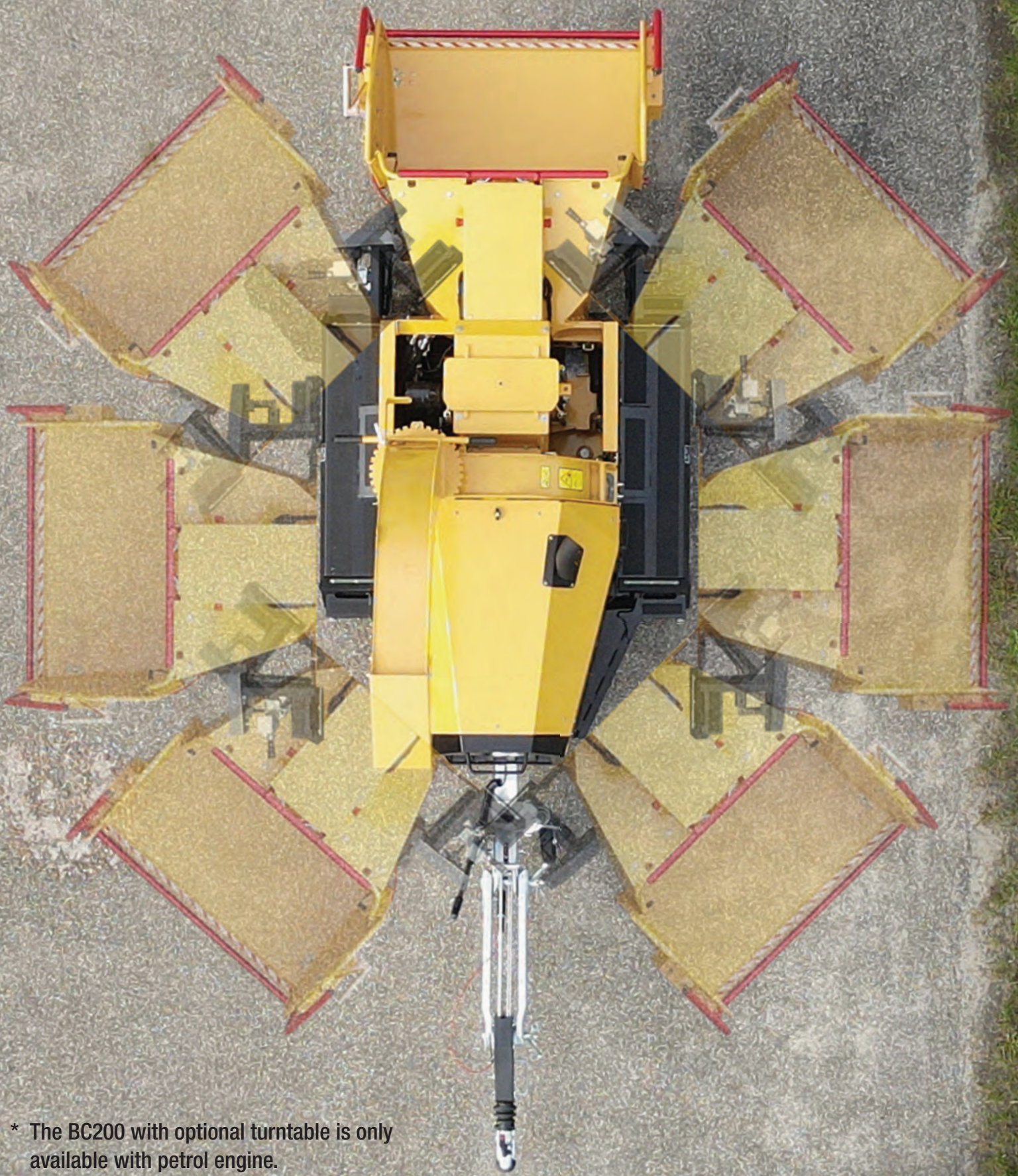

* The BC200 with optional turntable is only available with petrol engine.



Seven-Position Turntable

The chipper infeed can be rotated into seven positions to face the material for ease of feeding and convenience when working along the roadside. A lever on the side of the infeed table allows operators to adjust positions in minimal time.

Height-adjustable surge brake

Optional height-adjustable surge brake is designed for use with most transport vehicles.

Double axle

To support the added weight of the turn table, an AL-KO(R) 1350 double axle provides optimal stability and drivability.



The Vermeer 3-year coverage

The BC200 comes with 3-year service coverage on select components with an option to extend up to 5 years/5,000 hours. It's a smart way to help protect your investment.



**SCAN THE QR CODE
TO FIND YOUR LOCAL
VERMEER DEALER.**



VERMEER PARTS AND SUPPORT

You can expect sound service from Vermeer dealer service technicians when and where you need it most. From our application insight to our confidence at the counter, Vermeer will work to answer your requests with expert care and promptness. We know your machines better than anyone. Dependability matters when machines need service. We take pride in resolving issues the first time, helping you maximize your productivity.

Your Vermeer customer service experience matters to us. We know you want to keep your equipment and your crew running strong. When it comes to parts, your Vermeer dealer will work to get what you need in the least amount of time — because when you need a part, you need it now. Vermeer and regional Vermeer dealerships focus on serving your needs quickly, consistently and efficiently. That's the Vermeer way.



BC200 BRUSH CHIPPER

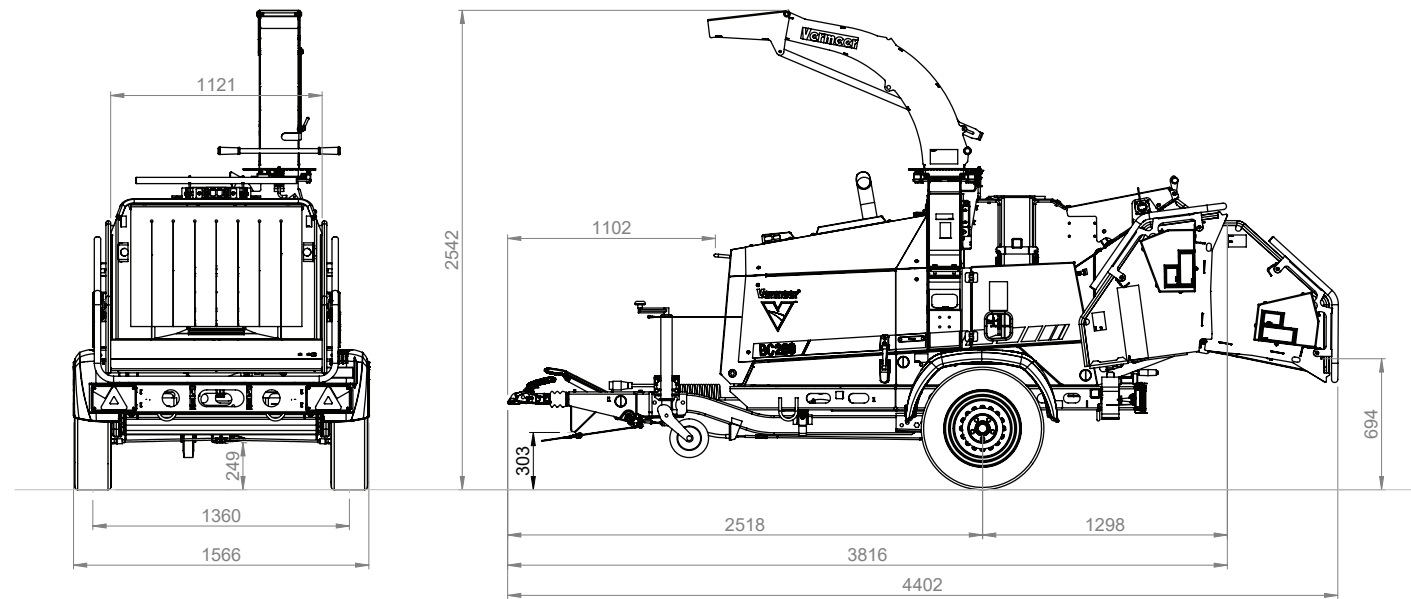

BC200 BRUSH CHIPPER WITH OPTIONAL TURNTABLE

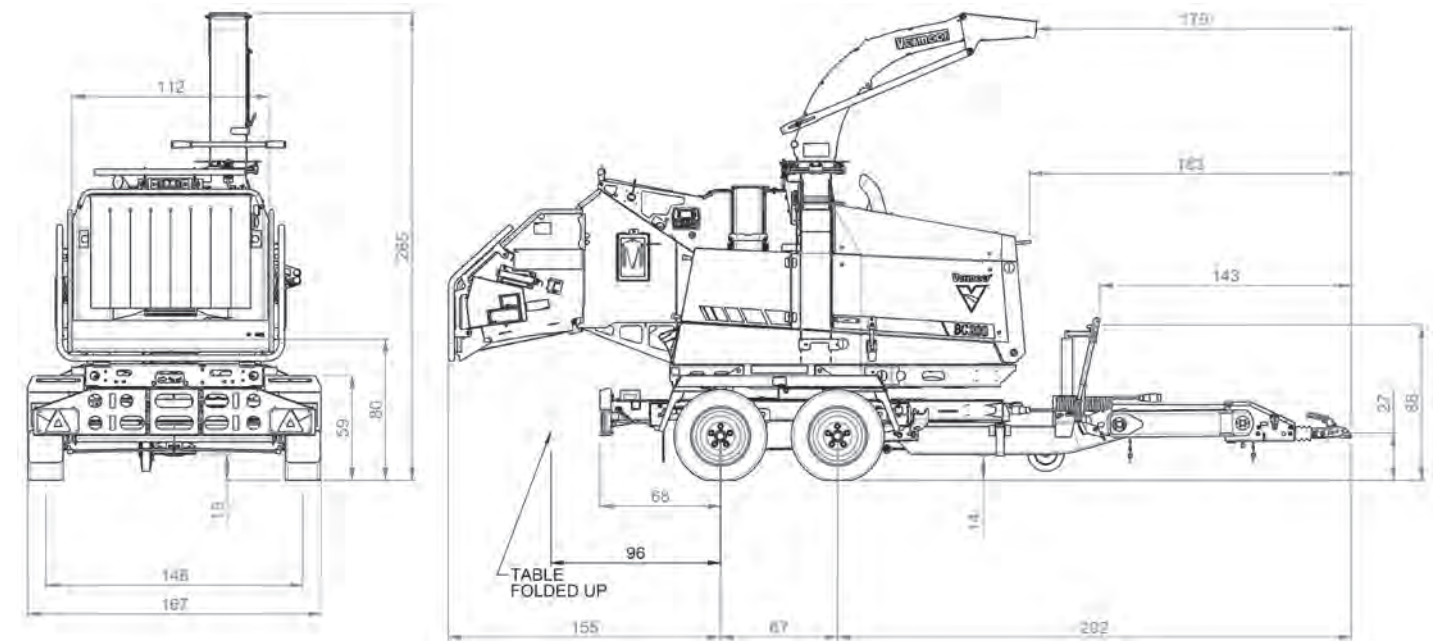

SPECIFICATION	BC200 BRUSH CHIPPER
GENERAL DIMENSIONS AND WEIGHTS	
Length — feed table up, tongue in	377 cm (148.4 in)
Length — table down, tongue extended	435 cm (171.3 in)
Max width (operation)	157 cm (61.8 in)
Max height (operation)	251 cm (99 in)
Weight — diesel engine	1.525 kg (3.300 lb)
Weight — petrol engine	1.465 kg (3.230 lb)
ENGINE OPTIONS	
Diesel make and model	Kubota V1505-CR-TE5
Max gross horsepower	44,3 hp (33.0 kW)
Fuel tank capacity	39,5 L (10.5 gal)
Clutch type	Direct drive
Petrol make and model	Kubota WG1605
Max gross horsepower	57 hp (42.5 kW)
Fuel tank capacity	39,5 L (10.5 gal)
Clutch type	Direct drive

SPECIFICATION	BC200 BRUSH CHIPPER
FEED SYSTEM	
Infeed roller dimension (1)	40 cm (15.8 in)
Infeed roller dimension (2)	26 cm (10.2 in)
Roller clamp force	396 kg (873 lb) spring loaded
Infeed opening	20,3 cm x 30,5 cm (8 in x 12 in)
Infeed table width	114 cm (44.9 in)
Infeed table length	70 cm (27.6 in)
Infeed hopper height	79 cm (31.1 in)
HYDRAULIC SYSTEM	
Tank capacity	22,7 L (6 gal)
OTHER OPTIONS	
Special paint	All RAL colors available

SPECIFICATION	BC200 BRUSH CHIPPER WITH OPTIONAL TURNTABLE
GENERAL DIMENSIONS AND WEIGHTS*	
Minimum length, fixed drawbar	414 cm (163 in)
Maximum length, HAS drawbar	455 cm (179 in)
Max width (operation)	167 cm (65.7 in)
Max height (operation)	265 cm (104 in)
Min-max height HAS drawbar	17 cm - 81 cm (6.7 - 31.9 in)
Weight with fixed drawbar	1.810 kg (3.990 lb)
Weight with HAS drawbar	1.840 kg (4.060 lb)
Tongue weight fixed drawbar	100 kg (220 lb)
Tongue weight HAS drawbar	110 kg (240 lb)
ENGINE	
Make and model	Kubota WG1605
Max gross horsepower	57 hp (42.5 kW)
Fuel tank capacity	39,5 L (10.5 gal)
Max fuel consumption	7 L/hr (1.8 gph)
Fuel type	Unleaded gasoline 95 octane max 10% methanol
Max angle of continuous operation	30°
Clutch type	Direct drive

SPECIFICATION	BC200 BRUSH CHIPPER WITH OPTIONAL TURNTABLE
FEED SYSTEM	
Top infeed roller diameter	40 cm (15.8 in)
Bottom infeed roller diameter	26 cm (10.2 in)
Roller clamp force	396 kg (873 lb) spring loaded
Infeed opening	20,3 cm x 30,5 cm (8 in x 12 in)
Infeed table width	114 cm (44.9 in)
Infeed table length	70 cm (27.6 in)
Distance from feed table to ground	80 cm (31 in)
HYDRAULIC SYSTEM	
Tank capacity	22,7 L (6 gal)
Biodegradable oil	Optional
OTHER OPTIONS	
Special paint	All RAL colors available
Height adjustable drawbar (HAS)	Available
Fixed drawbar	Available

*The height adjustable surgebrake option is shown.
*The optional turntable is only available with petrol engine.

Vermeer EMEA

Europe, Middle East and Africa

P.O. Box 323

4460 AS Goes

The Netherlands

+31 (0) 113-272700 • vermeer.com

Vermeer Manufacturing International Goes reserves the right to make changes in engineering, design and specifications; add improvements; or discontinue manufacturing at any time without notice or obligation.

Equipment and depictions shown are for illustrative purposes only and may display optional accessories or components specific to their global region. Please contact your local Vermeer dealer for more information on machine specifications.

Vermeer, the Vermeer logo and Ecolde are trademarks of Vermeer Manufacturing Company in the U.S. and/or other countries. Kubota is a trademark of Kubota Engine Corporation. AL-KO is a trademark of AL-KO Kober A.G.

© 2025 Vermeer Corporation. All Rights Reserved.

240932 12/24



BC200 BRUSH CHIPPER